



IMPIANTI COMPLETI SCORREVOLI
TOTAL SLIDING SYSTEM

SYSTEM LINE

I SYSTEM LINE

Kit di aspirazione per linee di revisione auto, comprendente:

- Linea canalina sez. 135x220 (mod. BLIND 190) L = 9, 12, 15 mt. con carrello di scorrimento
- Tubo flessibile (Ø 75 mm - lunghezza 5 mt.)
- Bocchetta in gomma con pinza
- Elettroaspiratore in fusione di alluminio antiscintille ad alta pressione mod. ASP 0.75 HP 0.75
- Tubo flessibile Alluflex di collegamento linea/aspiratore.

Fornibile nelle seguenti versioni:

- Manuale con sgancio bocchetta e ritorno
- Automatico con sgancio bocchetta automatico, attacco rapido di sicurezza, ritorno elettrico (optional).

N.B. Lo staffaggio della linea non è compreso. Camino Ø 120 mm e linea di collegamento sono da conteggiarsi in loco.

Per ogni altra informazione consultare ns. Uff. Tecnico.

GB SYSTEM LINE

The extraction kit includes:

- Aluminium extraction rail (135x220), length = 9, 12 or 15 mt. (mod. BLIND 190) with sliding trolley
- Flexible hose (Ø 75 mm - length 5 mt.)
- Rubber nozzle with gripper
- Sparkproof cast aluminium electric exhauster high pressure (ASP 0.75 - HP 0,75).
- Alluflex hose to joint the line and the exhauster.

Available in the following versions:

- Manual, after the nozzle is manually uncoupled the sliding trolley has to be accompanied to its parking place.
- Automatic uncoupling of the nozzle supplied with safety quick coupling system - electric recovery of the trolley (optional).

Track brackets are not included, the chimney Ø 120 mm and the jointing line are to be studied on the spot. For further information, please apply to our technical office.



SYSTEM LINE VP

I SYSTEM LINE VEICOLI PESANTI.

Kit scorrevole per revisione camion completo di elettroaspiratore da 2 HP, un carrello con 7,5 mt di tubazione Ø 150, bilanciere con contro scatto e bocchetta ovale in gomma per scarichi accoppiati con pinza manuale. Escluso staffe soffitto/parete e camino Ø 200. Versione manuale: sgancio bocchetta manuale e ritorno carrello a inizio linea manuale.

GB SYSTEM LINE FOR HEAVY VEHICLES.

Complete heavy vehicles overhauling sliding kit furnished with 2 HP electric exhauster, sliding carriage with 7,5 -mt- long Ø 150 hose, equalizer with counter-release and oval rubber nozzle for twin exhaust-pipes with manual locking gripper. Wall and ceiling fastening hangers and Ø 200 outlet hose are excluded.

Manual version: manual nozzle uncoupling and manual trolley recovery.

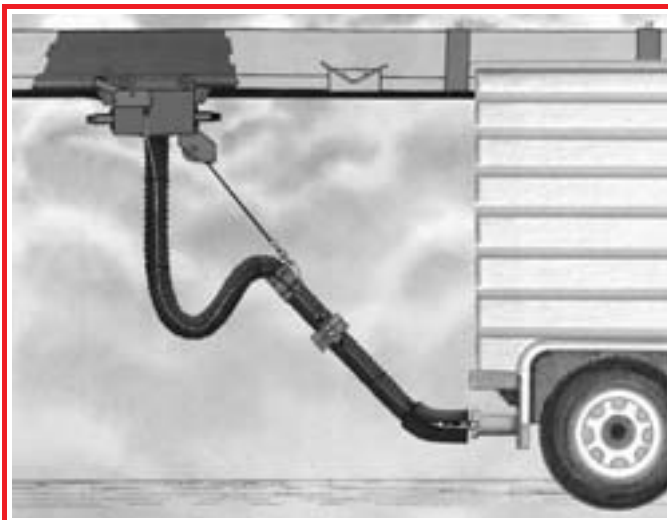

Versione automatica a richiesta. Consultare il ns. ufficio tecnico commerciale.

Automatic version on request. Please apply to our sales office for further information.

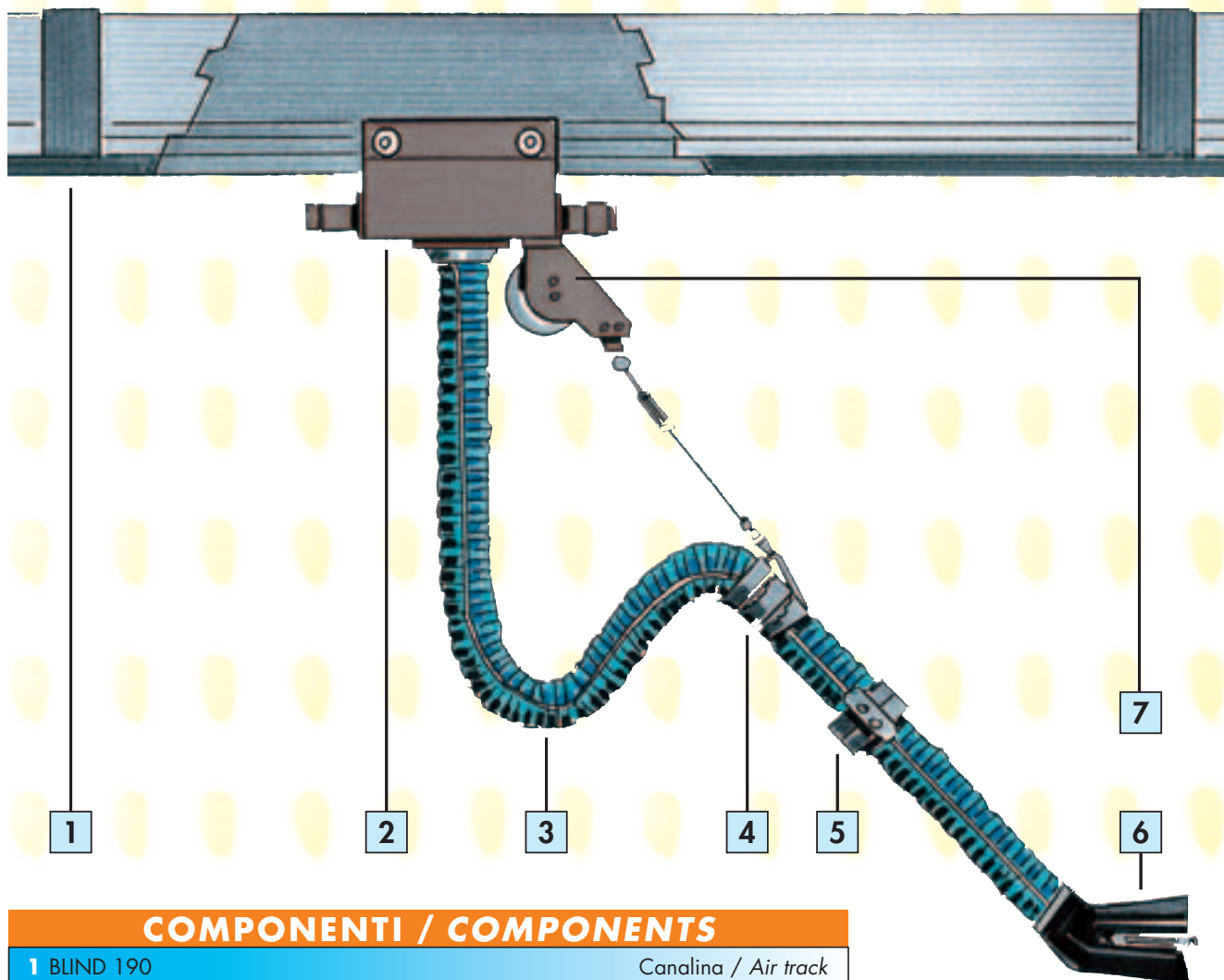

COMPONENTI / COMPONENTS

1	BLIND 190	Canalina / Air track
2	CAT 75	Carrello scorrevole / Sliding carriage
3	T-GAS 75/5	Tubazione flessibile / Flexible hose
4	AN 75	Attacco per sospensione / Coupling for hose suspension
5	JOINT 75 (Optional)	Attacco rapido / Quick hose coupling
6	BNA 75 P	Bocchetta ovale in gomma / Oval rubber nozzle
7	BIL	Bilanciere / Equalizer

